

*Universitas Galatiensis*

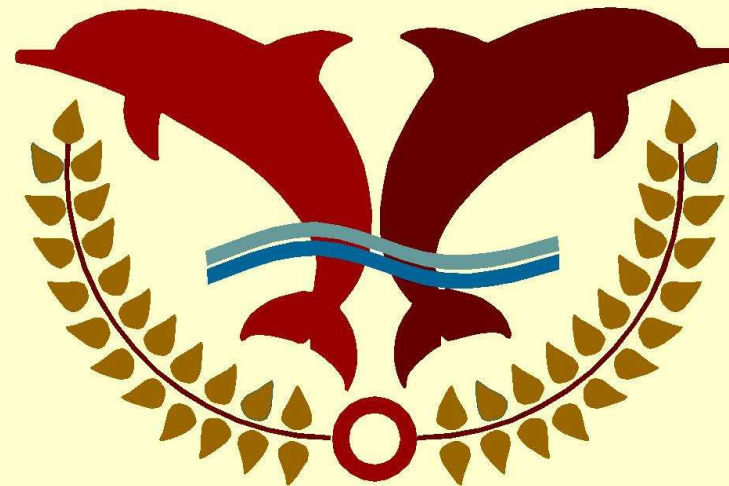

**FACULTY OF NAVAL ARCHITECTURE**

**"DUNAREA DE JOS" UNIVERSITY OF GALATI**



# Topics

- Romania
- Galati City
- "DUNAREA DE JOS" University of Galati
- Faculty of Naval Architecture
- EMShip 4<sup>th</sup> semester (Track 2) in Galati



# Romania

Romania lies in the  
Central-South-Eastern  
part of the Europe



# The City of Galati

Galati is the 7<sup>th</sup> greatest city of Romania (about 250000 inhabitants) (since 1445)



Galati is situated

- about 250 km North-East of the capital Bucharest
- not far from the famous Danube Delta.
- on the bank of the Danube river
- at 150 Km (80 MM) from the Black Sea



The town industry consist of iron and steel processing and shipbuilding.

Largest center in metal processing industry Arcelor-Mittal (since 1966) and the oldest shipyard Damen in Romania (since 1893).



Faculty of Naval A

# "DUNAREA DE JOS" University of Galati

(Since 1948) [www.ugal.ro](http://www.ugal.ro)



- Engineering;
- Food Science and Engineering;
- **Naval Architecture;**
- Computer Science and Electrical Engineering;
- Sciences;
- Economic Sciences;
- Law, Social and Political Sciences;
- History, Philosophy and Theology;
- Letters;
- Medicine;
- Physical Education and Sport;
- Arts;
- Engineering at Braila
- Sciences and Engineering Kahul (Rep.Moldova)

14 faculties over 11000 students  
Academic programs:  
65 bachelor degree programs  
48 Master programs  
30 PhD degree programs



Faculty of Naval Architecture

"Dunarea de Jos" University of Galati



# Faculty of Naval Architecture



(Since 1951) [www.naoe.ugal.ro](http://www.naoe.ugal.ro)

Educational offer:

## 2 Bachelor programs:

- Naval Architecture (in En,Ro)
- Ship Systems (in Ro)

## 2 Master programs:

- Naval Architecture (in En)
- Advanced Shipbuilding Technologies (in En)

## 1 PhD program:

- Ships' Hydrodynamics and Structures – Mechanic Engineering (in Ro)

- The oldest Romanian Higher Education Institution in Naval Architecture
- The only faculty all over the country that has a widely recognized tradition in the numerical and experimental research related to the ship hydrodynamics and structures;
- A faculty that benefits of adequate infrastructure and facilities for research (**towing tank, cavitation tunnel** – both unique in the country for almost forty years and still unique in the Romanian Higher Education Institution, ship equipment labs, etc);



"Dunarea de Jos" University of Galati



# Faculty of Naval Architecture

Research – 2 main directions:

Ship Hydrodynamics

Ship Structures Analysis

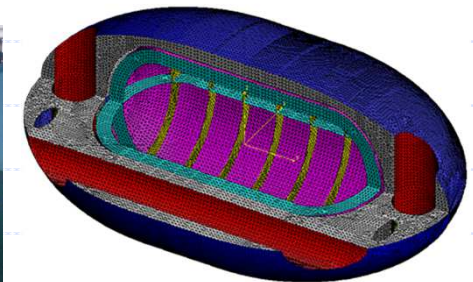
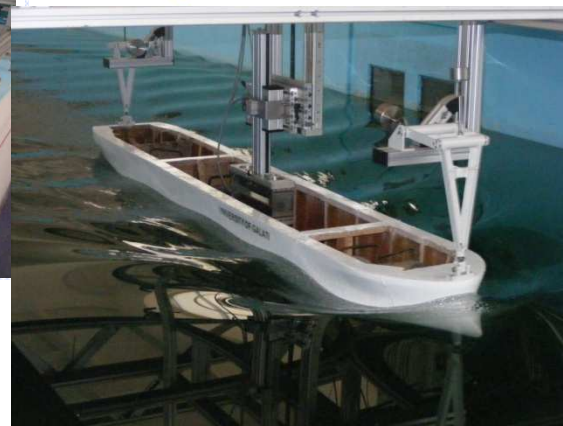
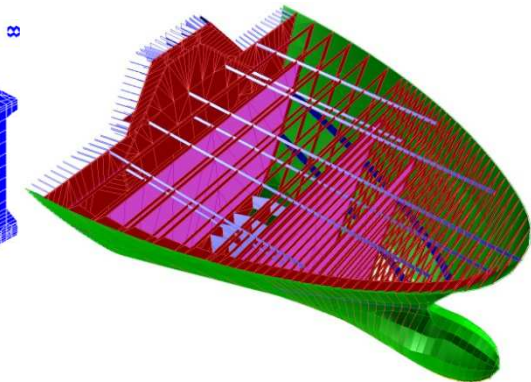
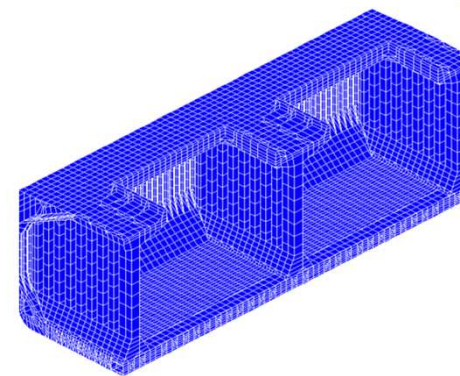
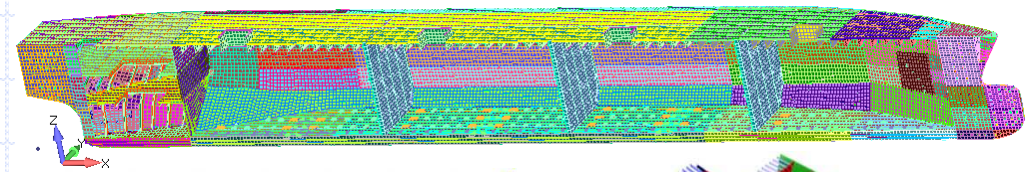
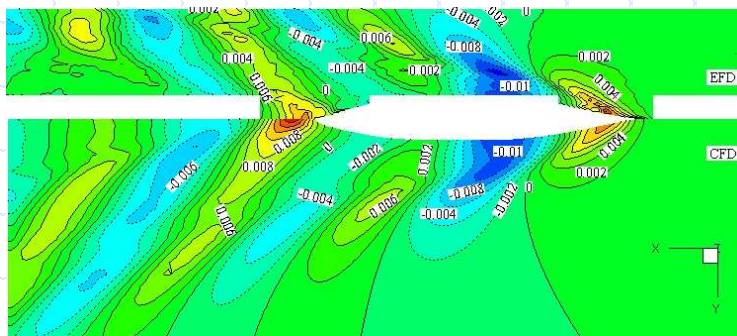

# EMShip 4<sup>th</sup> semester in Galati (UGAL) Track 2



- Lectures (10 ECTS) - **Ship Manoeuvrability and Propulsion** :
  - S4-UGAL-1 SHIP PROPULSION (5 ECTS)
  - S4-UGAL-2 SHIP MANOEUVRABILITY (5 ECTS)
- Internship (5 ECTS): ICE ICEPRONAV Galati, SDG Ship Design Group Galati, UGAL, BV Bureau Veritas Romania, NAVYK Galati, DSG Damen Shipyards Galati (*selection only by UGAL team*)
- Master theses (15 ECTS)
- General information

Contact E-mail UGAL team: [Leonard.Domnisoru@ugal.ro](mailto:Leonard.Domnisoru@ugal.ro) , [Florin.Pacuraru@ugal.ro](mailto:Florin.Pacuraru@ugal.ro)  
 International Students Office: [Alexandru.Praisler@ugal.ro](mailto:Alexandru.Praisler@ugal.ro)

Arrival in Galati	Beginning of March
Internship at Romanian Companies in Galati	Beginning of March till June
Start for Master Thesis	Beginning of March
Start of lectures for EMship students at UGAL Ship Manoeuvrability and Propulsion (in Galati)	Beginning of March, in parallel to the Internship
Lecture: S4-UGAL-1 (Lecture & applications) Ship Propulsion / Prof. Amoraritei M.	March – May (40 h – 10 weeks)
Lecture: S4-UGAL-2(A) (Lecture) Ship Manoeuvrability / Prof. Obreja D.C.	March – May (20 h – 10 weeks)
Lecture: S4-UGAL-2(B) (CFD applications) Ship Manoeuvrability / Prof. Pacuraru F.	March – May (20 h – 10 weeks)
Exams: Ship Manoeuvrability and Propulsion	June
Deadline for Master Thesis	July
Defence of Master Thesis (public workshop)	Around 20 <sup>th</sup> of July or Beginning of September
Summer Holidays University is closed	End of July – End of August
Grades Report for EMship students at UGAL	July or Beginning of September
Leaving Galati for EMship week	September
EMship week at Istanbul	September



# Lectures – Ship propulsion

Code: EMSHIP S3-UGAL-1 (Semester 4 Track 2)

Workload: 20 h lecture & 20 h applications (10 weeks)

Number of credits: 5 ECTS

- The objective is to provide the specific knowledge about the ship propulsion devices, taking into consideration not only the classical propulsion means (screw propellers), but also the unconventional ones.

The course will focus on:

- Fundamentals of propeller theory;
- Flow mechanisms;
- Cavitation;
- Propeller design and analysis;
- Unconventional propulsion arrangements;
- Energy saving devices;
- Trends ship propulsion;
- Experimental investigation

- Lecturer: Professor Mihaela Amoraritei

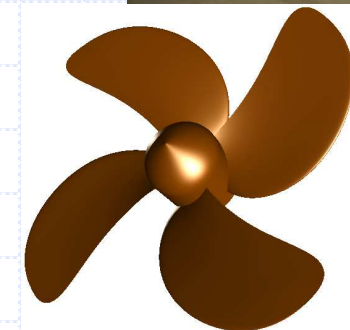
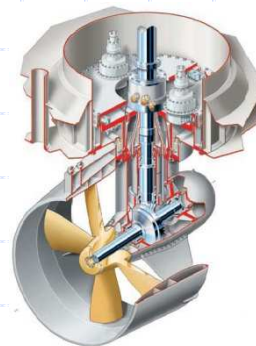
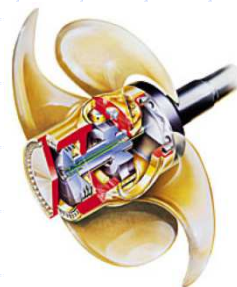
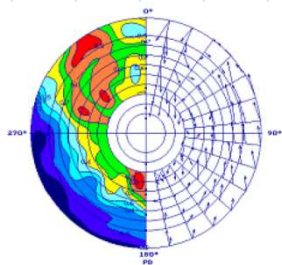
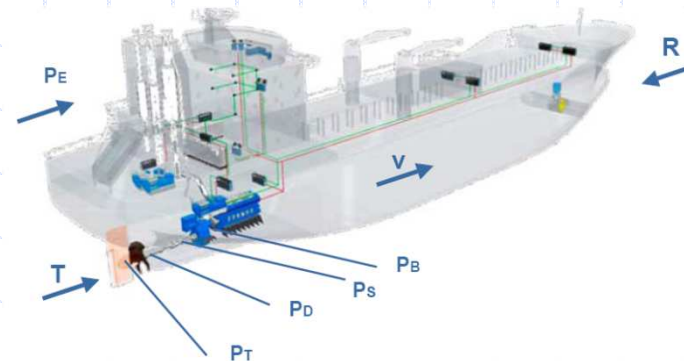

# Lectures - Ship Manoeuverability

Code: EMSHIP S4-UGAL-2 (Semester 4 Track 2)

Workload: 20 h lecture & 20 h applications (10 weeks)

⊕ Number of credits: 5 ECTS

- The objective is to provide the specific knowledge in the ship manoeuverability.
- The course will cover:
  - Mathematical models of the ship manoeuverability
  - Experimental investigations of the hydrodynamic derivatives
  - Standard ship manoeuvres
  - Passive control surfaces: rudder hydrodynamic forces and moments, interaction between hull-propeller-rudder
  - Active control devices

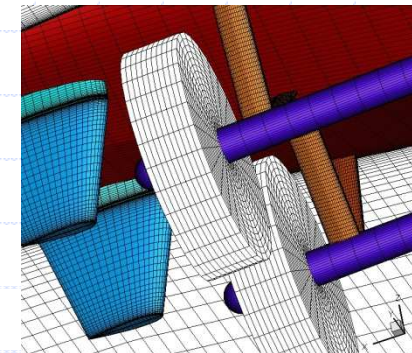
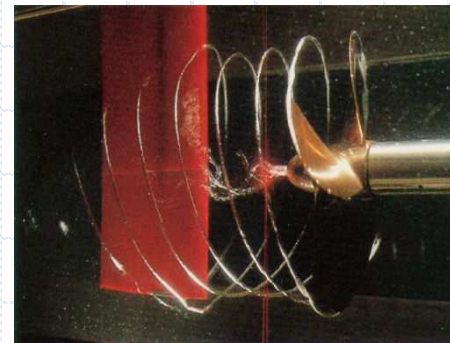
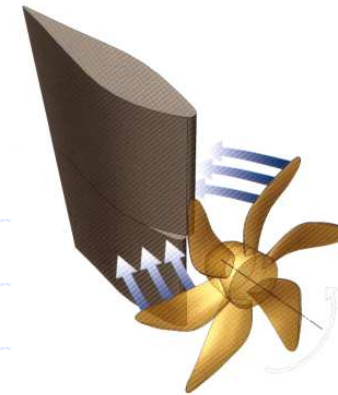

- Applications:
  - CAD-CAE tools for manoeuvrability performance calculation (Aveva code – Initial Design, Manoeuvrability module)
  - CFD tools for rudder design (Shipflow code).

Lecturers: Professor Dan Obreja  
Professor Florin Pacuraru

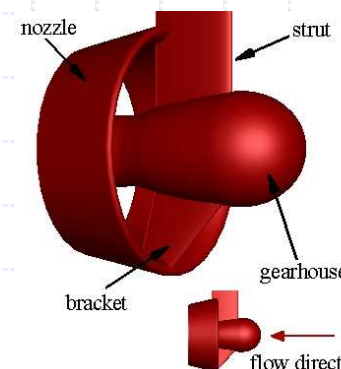

# Internship

## ICE ICEPRONAV S.A. GALATI

**Profile:** Ship Design and Research in Shipbuilding

1 candidate



The ICE Group offers a complete range of ship design services:

- basic design,
- development of class drawings,
- detail design,
- generation of production information
- sea trials assistance.

ICE has been involved in the design commercial vessel, ranging from fishing vessels to large bulk carriers, chemical and gas tankers, offshore drill and FPSO, navy.

### Contact: ICE ICEPRONAV S.A.

19A Portului Street, 800025, Galati, Romania

Phone: +40 236 415 965,

Fax: +40 236 417 836,

Web: [www.icepronav.ro](http://www.icepronav.ro)

E-mail: [alina.florea@icepronav.ro](mailto:alina.florea@icepronav.ro)



Faculty of Naval Architecture

"Dunarea de Jos" University of Galati



# Internship



## SDG SHIP DESIGN GROUP GALATI

**Profile:** Ship Design and Research in Shipbuilding

1 candidate

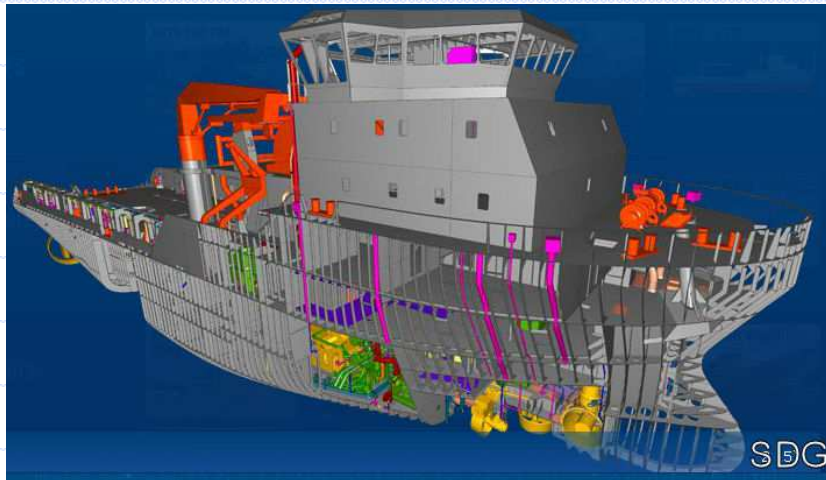

The SDG Group offers a complete range of ship design services:

- basic design,
- development of class drawings,
- detail design,
- generation of production information.

SDG has been involved in the design of offshore vessels, tugs & pushers, cargo vessels, dedicated special vessels.

### Contact: SDG Ship Design Group

51 Dogariei Street, 800225, Galati, Romania

Phone: +40 236 476 672,

Fax: +40 236 460 336,

Web: [www.shipdesigngroup.eu](http://www.shipdesigngroup.eu)

E-mail: [o.ionas@shipdesigngroup.eu](mailto:o.ionas@shipdesigngroup.eu)



Faculty of Naval Architecture

# Internship

- **Bureau Veritas Romania**
- **Profile:** Class
- 1 candidate



Contact:

Address: 165b, Brailei Street, 5th Floor, 800310 Galati

Phone + 40 236 499 290

Fax + 40 236 499 297

Web: [www.bureauveritas.ro](http://www.bureauveritas.ro)

Email: [jean-sever.popovici@ro.bureauveritas.com](mailto:jean-sever.popovici@ro.bureauveritas.com)



# Internship



- **Profile:** Yacht Design
- 1 candidate

Contact:

Address: 6, Tecuci Street, 800120 Galati

Phone: + 40 336 802 145

Fax: + 40 336 802 146

Web: [www.navyk.com](http://www.navyk.com)

Email: [o.niculet@navyk.com](mailto:o.niculet@navyk.com)  
[s.terhorst@navyk.com](mailto:s.terhorst@navyk.com)

ALLOCATION AFTER TYPE/LENGTH OF CRAFT

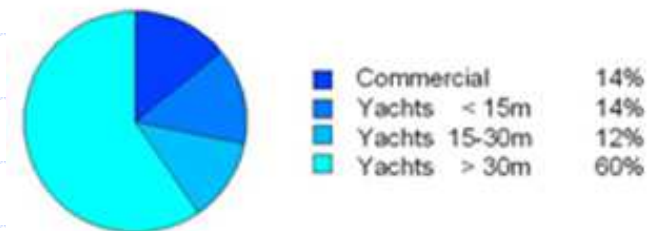

ALLOCATION AFTER SERVICE

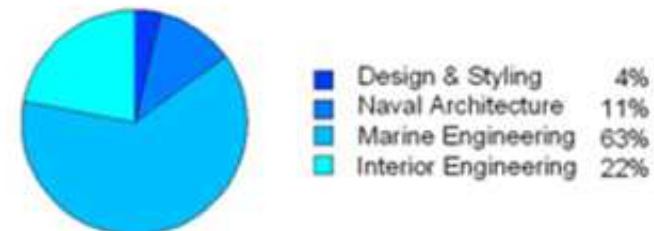

# Internship

- **Damen Shipyards Galati**
- **Profile:** Shipbuilding and Ship repair
- 1 candidate

**Contact:** Human Resources Department  
132 Moruzzi Street 800223 Galati  
Phone: +40 236 307 122  
Fax: + 40 236 307 122  
Web: [www.damen.ro](http://www.damen.ro)  
Email: [humanresources@damen.ro](mailto:humanresources@damen.ro)



Some of the products manufactured by DSG are: chemical tankers, container carriers, hopper dredgers, navy vessels, tugs/workboats, drilling rig.

Their currently order book as well as their future targets are focused on more advanced and high technology vessels, including naval vessels, tugs & workboats, special vessels, mega yachts.



Faculty of Naval Architecture

"Dunarea de Jos" University of Galati



# Internship

- UGAL



- **Profile:** Education and research
- 1- 2 candidates

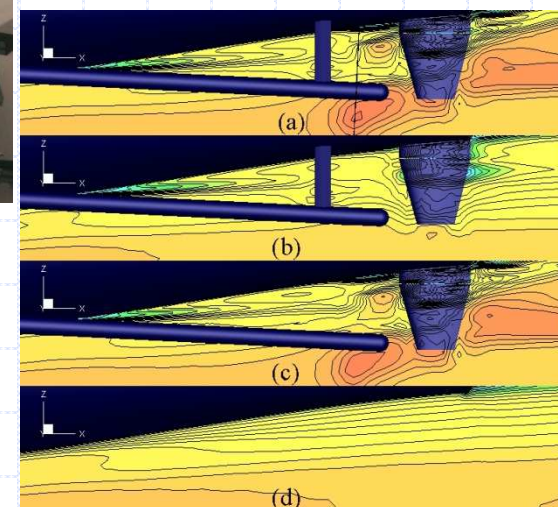
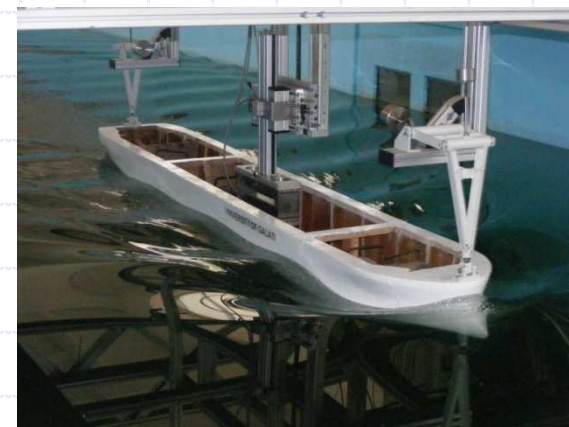

Contact:

47, Domneasca Street, 800008, Galati

Phone: + 40 336 130 230

Fax: + 40 236 495 400

Web: [www.ugal.ro](http://www.ugal.ro)

Email: [florin.pacuraru@ugal.ro](mailto:florin.pacuraru@ugal.ro)



Faculty of Naval Architecture

"Dunarea de Jos" University of Galati



# Master thesis/internship from previous cohorts at UGAL semester

- Turbulent Flow Separation around a ROV Body / ICE ICEPRONAV SA Galati
- The Design of a Bulk Carrier Propulsion System / ICE ICEPRONAV SA Galati
- Numerical Investigation of the Hydrodynamic Performances of Marine Propeller / ICE ICEPRONAV SA Galati
- The Design of a Containership Propulsion System / ICE ICEPRONAV SA Galati
- Numerical Simulation of the Flow Field around a Propeller / ICE ICEPRONAV SA Galati
- Hydrodynamics Forces and Moments on KVLCC2 Hull, with Drift Angle and Rudder Angle Influences / SDG Ship Design Group Galati
- Hydrodynamic Performances Analysis and Design of a Containership Propeller / SDG Ship Design Group Galati
- Hydrodynamic Performances of KRISO Container Ship (KCS) Using CAD-CAE and CFD Techniques / SDG Ship Design Group Galati
- Hydrodynamic studies on Hull-Propeller-Rudder Interaction / Damen Shipyards Galati
- Numerical Investigation of Flow around an Appended Ship Hull / Damen Shipyards Galati
- Numerical Simulation of Free Surface Flows around Ship Hull / NAVYK Galati
- Standard Manoeuvres Simulation of a Fishing Vessel / BVR Bureau Veritas Romania, Galati
- Numerical simulation of the 3D flow around Junctures / “Dunarea de Jos” University of Galati

# General Information – Living in UGAL campus

UGAL pays a special attention to the accommodation of Romanian students and foreign students who came to in Galati through International Programs.

Accommodation in student hostel ~ **100 EURO/month**  
& local offers by UGAL International Students Office.



The students who eat at the UGAL canteen receive substantial funding from Romanian Ministry of Education, Research, Youth and Sport.

Lunch (first course, main course and desert) ~ **3-5 EURO**

All foreign students who come to study in Romania have the same rights as the Romanian students as far as the **medical insurance** is concerned, which means that all students **under the age of 26** who are not employed have the right to medical insurance, automatically.



# General Information

## **Embassy of Romania in the French Republic**

Address: 5, Rue de l'Exposition 75007, Paris  
CEDEX 07

Phone: 0033-1-47.05.10.46; 0033-1-47.05.18.70

Phone Consular Section: 0033-1-47.05.27.55

Phone Economic Section: 0033-1-47.05.12.74

Fax: 0033-1-45.56.97.47

Website: <http://paris.mae.ro/>

E-mail: [secretariat@amb-roumanie.fr](mailto:secretariat@amb-roumanie.fr)

## **Required valid Visa type long-stay (marked D)**

- starting 1 July (90 days & extended in Galati)

For age over 26 years old required standard medical insurance (to be solved in France)

Have to arrive in Galati no late than 5-th March so that the internship can start at beginnig of March.

Bucharest – Galati transport by train ([www.cfr.ro](http://www.cfr.ro))



Faculty of Naval Architecture

## **Embassy of Romania in the Kingdom of Belgium**

Address: 105, Rue Gabrielle, 1180 Bruxelles, Belgique

Fax: 0032-2-346.23.45

Phone: 0032-2-345.26.80

### **Consular Section**

Phone: 0032-2-343.69.35

Fax: 0032/23469814

E-mail: [secretariat@roumanieamb.be](mailto:secretariat@roumanieamb.be)

Web Site: <http://bruxelles.mae.ro/>

### **Romanian Information Center in Brussels**

Address: 107 Rue Gabrielle 1180 Bruxelles

Phone: +32 2 344 41 45 Fax: + 32 2 344 24 79

Web: [www.roinfocentre.be](http://www.roinfocentre.be) ([crib.mae.ro](http://crib.mae.ro))

E-mail: [office@roinfocentre.be](mailto:office@roinfocentre.be)

**See UGAL-Handbook for more informations**

"Dunarea de Jos" University of Galati



Romanian EMShip UGAL team look forward to seeing you in Galati..

